

Heat Capacities of Five Mixtures and Emulsion of Buna-S

Xiaoming Zhao,* Zhigang Liu, and Zhongqi Chen

State Key Laboratory of Multiphase Flow in Power Engineering, Xi'an Jiaotong University, Xi'an, Shaanxi 710049, China

The heat capacities of five mixtures used in the synthetic process of buna-S and an emulsion of buna-S were measured by means of an automated adiabatic calorimeter developed for heat capacity from 240 K to 400 K. Two sample vessels (A and B) are used with the calorimeter. The A-sample vessel is made of silver for measurement at atmosphere pressure. The heat capacities of α -Al₂O₃ (solid) and C₇H₁₆ (heptane in liquid) were measured with the calorimeter using the A-sample vessel, and the deviation of heat capacities between our results and the literature amounts to 0.16 % for α -Al₂O₃ and 0.28 % for C₇H₁₆. The B-sample vessel is made of copper for measurement at pressures up to 0.2 MPa. The calorimeter with the B-sample vessel was verified by measuring heat capacities of water, and the maximum relative difference with literature values is 0.33 %.

Introduction

The specific heat capacity of substance is not only one of the most important thermophysical property but also characteristic data concerned with the structure of a substance. It is widely used in physics and chemistry as well as in chemical engineering, energy resources, and material engineering. The specific heat capacity is also an important parameter for examining equations of state. The basic data are demanded in modern industrial and engineering designs. Reliable data are the basics for successful designs, which is a major purpose of thermophysical property research. There are two methods for obtaining the heat capacities of a substance: One is by calculation, including theoretical and correlating formulas, which for simple molecules is economical, but the agreement for more complete substances is not satisfactory. The other method is a direct measurement that can give accurate values, meeting the needs of engineering designs. The measurement of heat capacity of gases and liquids is more difficult than that of solids because their heat capacities depend significantly on temperature and pressure. There are many known calorimeters^{1–4} developed for measuring the heat capacity of fluids.

Buna-S is a kind of rubber widely used in the industry. It was synthesized with styrene and butadiene. To improve the synthetic process of buna-S, heat capacities of five mixtures, which are used in the synthetic process of buna-S, and an emulsion of buna-S were measured by an automated adiabatic calorimeter.

Experimental Section

Principle. In thermodynamics, the specific heat capacity at constant pressure is defined as $c_p = (\partial h/\partial T)_p$. It is difficult to determine $(\partial h/\partial T)_p$, usually one measures $(\Delta h/\Delta T)_p$. $(\Delta h/\Delta T)_p$ approximates to $(\partial h/\partial T)_p$ when ΔT is significantly small. The $\Delta h \times m$ equals the energy absorbed by the sample Q_p for an isobaric process. Thus, the heat capacity can be written as the following at temperature $T = \{(T_1 + T_2)/2\}$:

$$C_p = \frac{Q_p}{m(T_2 - T_1)} \quad (1)$$

* To whom correspondence should be addressed. E-mail: xzmzhao@mail.xjtu.edu.cn. Tel: +86-29-82666875. Fax: +86-29-82668789.

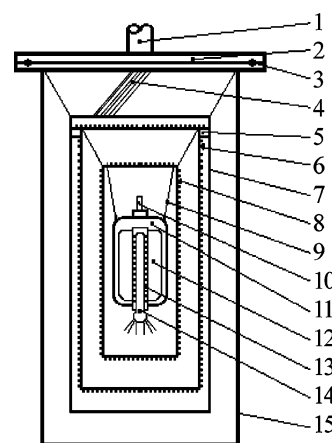

Figure 1. Adiabatic calorimeter: 1, tube for evacuation and drawing leads out; 2, cover of vacuum can; 3, sealing washer; 4, lead wires of thermometer and heater; 5, supporter; 6, outer shields; 7, guard shield; 8, inner shield; 9, silk threads for suspension; 10, tube of filling sample; 11, sample vessel; 12, radiating fins; 13, heater; 14, platinum resistance thermometer; 15, vacuum can.

where m is mass of sample; T_1 and T_2 are temperatures before and after heating, respectively.

Calorimeter. Figure 1 shows the arrangement of the main parts of the calorimeter. A sample vessel equipped with a platinum resistance thermometer and a heater at its center is surrounded by two (inner and outer) adiabatic shields and a guard shield. There are two sample vessels for the calorimeter. The A-sample vessel is a silver cylinder with a wall 0.2 mm thick and with radiating fins. The B-sample vessel is made of copper, and its walls are 0.4 mm. The vessel is about 35 mm in diameter and 65 mm in height, so the content of vessel is about 51.36 cm³. The multi-junction thermocouples between inner and outer adiabatic shields, the inner adiabatic shield, and the outer wall of sample vessel are connected to the temperature difference controller; thus, the automated adiabatic control is achieved. The calorimeter is hung with fiber wire in a vacuum can.

The platinum resistance thermometer (25 Ω , 5 mm diameter, 50 mm length) was made by the Instrument Manufactory of Yunnan, China, and calibrated with an accuracy of ± 2.5 mK on the ITS-90 scale at the National Institute of Metrology. The model of the thermometry bridge is QJ69, and the temperature uncertainty is 3 mK with a 100 Ω standard resistor. So, the un-

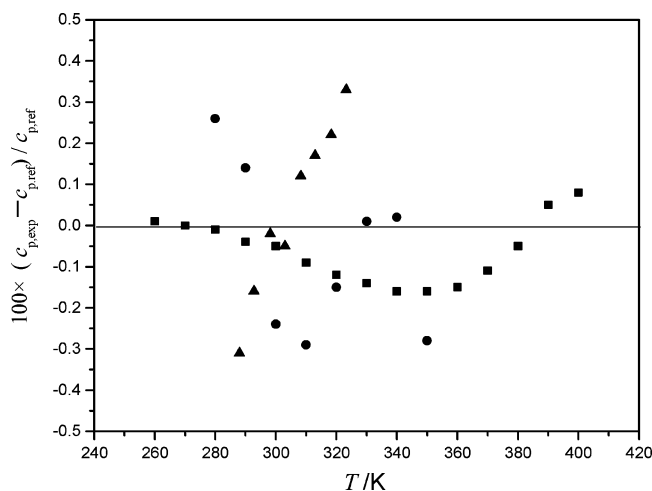

Figure 2. Deviations of experimental heat capacity of three substances: ■, heptane;⁵ ●, α -Al₂O₃;⁶ ▲, water.⁷

certainty of the measurement results is within ± 5.5 mK for temperature. The thermal energy measurement system consisted of the heater and a 10 Ω standard resistor. A voltage meter was used to measure the voltages of the heater and the standard resistor. The thermal energy generated by the heater can be determined by the voltages, standard resistor, and heating time. The uncertainty of the thermal energy measurement is better than ± 0.04 %. Taking into account the above factor, the uncertainty of heat capacity measurements is better than ± 0.47 %.

Verification of Calorimeter Performance. The part of the total energy Q' generated by the heater during the heating period was absorbed by the sample, and energy Q_0 was absorbed by the sample vessel. The energy obtained by the sample was

$$Q_p = Q' - Q_0 \quad (2)$$

Q' can be determined by means of current and voltage through the heater during heating. Q_0 must be measured on the empty sample vessel before measuring C_p of the sample.

α -Al₂O₃ and C₇H₁₆ (heptane) are standard substances for heat capacity measurement on solid and liquid, respectively. Their heat capacities were measured for checking up measurement accuracy and reliability of the calorimeter at atmosphere pressure. The mass purity of α -Al₂O₃ was 99.98 %, and the mass purity of heptane was 99.5 % with $n_D^{20} = 1.387$. The heat capacities of water (mass purity > 99.9 %) were also determined to check the calorimeter performance at 0.2 MPa. The experimental heat capacity of heptane, α -Al₂O₃, and water are shown in Figure 2.

The heat capacity values for α -Al₂O₃ of this work are reported in Table 1. On the basis of experimental heat capacities of α -Al₂O₃, a polynomial was fitted as the following function of temperature:

$$C_p/\text{J}\cdot\text{mol}^{-1}\cdot\text{K}^{-1} = -85.32303 + 1.0383 \times T/\text{K} - 0.00214 \times (T/\text{K})^2 + 1.70216 \times 10^{-6} \times (T/\text{K})^3 \quad (3)$$

The comparison of the fitted or smoothed values with those of NIST⁵ is also shown in Table 2. The maximum deviation of this work from NIST was +0.16 % from 300 K to 400 K. The experimental values of heat capacity are shown in Table 3 for heptane. The fitted polynomial for heptane was as follows:

$$C_p/\text{J}\cdot\text{mol}^{-1}\cdot\text{K}^{-1} = 1091.45261 - 8.71089 \times T/\text{K} + 0.02797 \times (T/\text{K})^2 - 2.85 \times 10^{-5} \times (T/\text{K})^3 \quad (4)$$

Table 1. Experimental Heat Capacities of α -Al₂O₃

T K	C_p J·mol ⁻¹ ·K ⁻¹	T K	C_p J·mol ⁻¹ ·K ⁻¹	T K	C_p J·mol ⁻¹ ·K ⁻¹
Series 1					
258.23	69.25	283.31	75.52	308.51	81.33
263.56	70.81	288.55	76.93	313.61	82.06
268.28	71.93	293.95	78.14	318.49	83.21
273.16	73.27	298.86	79.21		
278.37	74.54	303.66	80.03		
Series 2					
320.38	83.28	351.02	88.72	379.68	93.51
325.55	84.65	355.78	89.70	385.72	94.19
330.65	85.19	360.18	90.61	389.64	94.67
335.95	86.54	365.09	91.08	395.01	95.55
340.61	87.06	369.85	91.90	400.56	96.49
345.80	88.15	375.72	92.71		

Table 2. Comparison of the Results for α -Al₂O₃ of This Work with Those of the Literature⁵

T K	$C_p/\text{J}\cdot\text{mol}^{-1}\cdot\text{K}^{-1}$ this work	$C_p/\text{J}\cdot\text{mol}^{-1}\cdot\text{K}^{-1}$ lit ⁵	Devi ^a %	T K	$C_p/\text{J}\cdot\text{mol}^{-1}\cdot\text{K}^{-1}$ this work	$C_p/\text{J}\cdot\text{mol}^{-1}\cdot\text{K}^{-1}$ lit ⁵	Devi ^a %
260	69.77	69.75	0.01	340	87.04	87.18	-0.16
270	72.36	72.36	0.00	350	88.84	88.88	-0.16
280	74.83	74.84	-0.01	360	90.38	90.52	-0.15
290	77.16	77.19	-0.04	370	91.96	92.06	-0.11
300	79.37	79.41	-0.05	380	93.46	93.51	-0.05
310	81.45	81.52	-0.09	390	94.93	94.88	0.05
320	83.40	83.50	-0.12	400	96.35	96.27	0.08
330	85.27	85.39	-0.14				

^a Devi is defined as $100 \times (c_{p,\text{exp}} - c_{p,\text{ref}})/c_{p,\text{ref}}$.

Table 3. Experimental Heat Capacities of Heptane

T K	C_p J·mol ⁻¹ ·K ⁻¹	T K	C_p J·mol ⁻¹ ·K ⁻¹	T K	C_p J·mol ⁻¹ ·K ⁻¹
278.13	218.19	308.34	228.07	333.21	238.87
283.26	219.57	313.56	230.29	338.14	240.86
288.25	221.32	318.43	232.23	343.09	242.91
293.40	222.91	323.66	234.36	348.32	244.58
298.51	224.35	328.31	236.47	353.42	246.71
303.42	226.15				

Table 4. Comparison of the Results for Heptane of This Work with Those of the Literature⁶

T K	$C_p/\text{J}\cdot\text{mol}^{-1}\cdot\text{K}^{-1}$ this work	$C_p/\text{J}\cdot\text{mol}^{-1}\cdot\text{K}^{-1}$ lit ⁶	Devi ^a %	T K	$C_p/\text{J}\cdot\text{mol}^{-1}\cdot\text{K}^{-1}$ this work	$C_p/\text{J}\cdot\text{mol}^{-1}\cdot\text{K}^{-1}$ lit ⁶	Devi ^a %
280	218.80	218.23	0.26	320	232.90	233.25	-0.15
290	222.06	221.75	0.14	330	237.39	237.38	0.01
300	224.90	225.44	-0.24	340	241.72	241.67	-0.02
310	228.61	229.27	-0.29	350	245.40	246.09	-0.28

^a Devi is defined as $100 \times (c_{p,\text{exp}} - c_{p,\text{ref}})/c_{p,\text{ref}}$.

The comparison of the fitted values with those of NIST is also shown in Table 4. The maximum deviation of this work from NIST was -0.28 % from 280 K to 350 K. The above results were obtained by a calorimeter with the A-sample vessel at atmosphere pressure.

The heat capacities of water were measured with the B-sample vessel at 0.2 MPa as there was a mixture to be measured at that pressure. Table 5 shows a comparison of the measured heat capacities of water with those of the literature.⁵ The maximum deviation is +0.33 %. The above measurements validated the reliability and stability of the calorimeter.

Results and Discussion

Heat Capacities of Five Mixtures and Emulsion of Buna-S. The heat capacities of five mixtures used in the synthetic process of buna-S and the emulsion of buna-S were measured

Table 5. Comparison of the Results for Water of This Work with the Literature⁷ ($p = 0.2$ MPa)

T	$C_p/\text{J}\cdot\text{mol}^{-1}\cdot\text{K}^{-1}$		Devi ^a	T	$C_p/\text{J}\cdot\text{mol}^{-1}\cdot\text{K}^{-1}$		Devi ^a
K	this work	lit ⁷	%	K	this work	lit ⁷	%
288.01	4.173	4.186	-0.31	308.27	4.184	4.179	0.12
292.79	4.176	4.183	-0.16	313.03	4.186	4.179	0.17
298.18	4.180	4.181	-0.02	318.31	4.188	4.179	0.22
302.96	4.182	4.180	-0.05	323.24	4.194	4.180	0.33

^a Devi is defined as $100 \times (c_{p,\text{exp}} - c_{p,\text{ref}})/c_{p,\text{ref}}$.

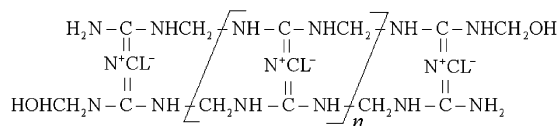
**Figure 3.** Molecular formula of the polymer flocculant.**Table 6. Heat Capacities of Sample 1**

T	C_p		T	C_p	
K	$\text{J}\cdot\text{g}^{-1}\cdot\text{K}^{-1}$	K	$\text{J}\cdot\text{g}^{-1}\cdot\text{K}^{-1}$	K	$\text{J}\cdot\text{g}^{-1}\cdot\text{K}^{-1}$
278.60	1.7748	300.43	1.8577	322.33	1.9677
285.02	1.7928	306.26	1.8641	326.44	1.9888
289.57	1.8088	311.72	1.9094	331.69	2.0144
294.73	1.8298	317.07	1.9455	337.16	2.0390

Table 7. Heat Capacities of Sample 2

T	C_p		T	C_p	
K	$\text{J}\cdot\text{g}^{-1}\cdot\text{K}^{-1}$	K	$\text{J}\cdot\text{g}^{-1}\cdot\text{K}^{-1}$	K	$\text{J}\cdot\text{g}^{-1}\cdot\text{K}^{-1}$
278.19	4.2206	294.08	4.2258	315.71	4.3138
282.51	4.2214	299.51	4.2285	320.58	4.3248
287.76	4.2219	304.95	4.2400	325.14	4.3635
293.13	4.2222	310.37	4.2727	330.15	4.3715

Table 8. Heat Capacities of Sample 3

T	C_p		T	C_p	
K	$\text{J}\cdot\text{g}^{-1}\cdot\text{K}^{-1}$	K	$\text{J}\cdot\text{g}^{-1}\cdot\text{K}^{-1}$	K	$\text{J}\cdot\text{g}^{-1}\cdot\text{K}^{-1}$
278.40	4.2429	296.36	4.2782	312.16	4.2942
284.14	4.2485	301.63	4.2889	317.44	4.3004
286.09	4.2561	306.90	4.2929	322.91	4.3073

with the calorimeter. Sample 1 contains 1 % *p*-tert-butylcatechol and 99 % styrene on a mass basis. Sample 2 contains 93 % water and 7 % polymer flocculant on a mass basis. The molecular formula of the polymer flocculant is shown in Figure 3.

Sample 3 contains 0.2 % sodium nitrite, 4 % sodium dimethyl dithiocarbamate, and 95.8 % water on a mass basis. The mass fractions in sample 4 are 1.3 % EDTA ferric monosodium salt, 1.8 % EDTA disodium salt, 7.5 % sodium formaldehydesulfoxylate, and 89.4 % water, respectively. The mass fractions of sample 5 are 0.5 % sodium abietate, 6 % sodium hydrate, 30 % *N*-phenyl-2-naphthylamine, and 63.5 % water. The emulsion of buna-S contains 1 % butadiene, 4 % styrene, 6 % water, and 89 % buna-S particulates on a mass basis. The mass purity of all the pure substances that compose the mixtures is higher than 99.5 %.

The experimental values for heat capacities of five mixtures and the emulsion of buna-S are listed in Table 6 to Table 11. All experiments were carried out at the ranges of the temperature required by production. The values of the emulsion of buna-S were measured at 0.2 MPa by means of the calorimeter with B-sample vessel. For each sample, a polynomial function of the type

$$C_p/\text{J}\cdot\text{g}^{-1}\cdot\text{K}^{-1} = a_0 + a_1 \times T/\text{K} + a_2 \times (T/\text{K})^2 \quad (5)$$

Table 9. Heat Capacities of Sample 4

T	C_p		T	C_p	
K	$\text{J}\cdot\text{g}^{-1}\cdot\text{K}^{-1}$	K	$\text{J}\cdot\text{g}^{-1}\cdot\text{K}^{-1}$	K	$\text{J}\cdot\text{g}^{-1}\cdot\text{K}^{-1}$
278.37	4.0802	297.11	4.0998	312.75	4.1181
283.50	4.0824	302.18	4.1110	318.06	4.1207
288.18	4.0867	307.47	4.1173	323.80	4.1224
292.48	4.0888				

Table 10. Heat Capacities of Sample 5

T	C_p		T	C_p	
K	$\text{J}\cdot\text{g}^{-1}\cdot\text{K}^{-1}$	K	$\text{J}\cdot\text{g}^{-1}\cdot\text{K}^{-1}$	K	$\text{J}\cdot\text{g}^{-1}\cdot\text{K}^{-1}$
278.65	3.5181	296.09	3.5845	312.50	3.6530
283.89	3.5377	299.36	3.6040	318.14	3.6564
287.98	3.5592	306.87	3.6220	323.28	3.6691

Table 11. Heat Capacities of Emulsion of Buna-S ($p = 0.20$ MPa)

T	C_p		T	C_p	
K	$\text{J}\cdot\text{g}^{-1}\cdot\text{K}^{-1}$	K	$\text{J}\cdot\text{g}^{-1}\cdot\text{K}^{-1}$	K	$\text{J}\cdot\text{g}^{-1}\cdot\text{K}^{-1}$
276.62	3.7664	288.28	3.7790	313.20	3.7791
278.76	3.7694	293.28	3.7783	318.20	3.7830
281.79	3.7732	298.25	3.7791	323.18	3.7854
282.77	3.7750	303.23	3.7786	328.16	3.7859
285.37	3.7762	308.22	3.7796	333.13	3.7987
287.26	3.7773				

Table 12. Parameters a_i of Equation 5

sample	a_0	a_1	a_2
sample 1	1.87719	-0.0046	0.0000151
sample 2	10.63955	-0.04521	0.0000796
sample 3	1.84564	0.01474	-0.0000221
sample 4	2.83249	0.00737	-0.0000104
sample 5	0.12298	0.01969	-0.0000269
emulsion of buna-S	3.91716	0.00126	0.00000264

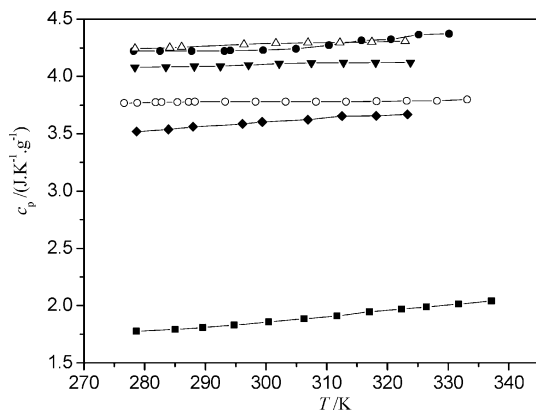
**Figure 4.** Heat capacities of five samples and the emulsion of buna-S: ■, sample 1; ●, sample 2; □, sample 3; ▼, sample 4; ○, sample 5; ○, emulsion of buna-S. Full curves represent the smoothing of eq 5 with the coefficients of Table 12.

was used to correlate the experimental values of C_p according to temperature with the method of least squares. The coefficients (a_i) in eq 5 are shown in Table 12. The polynomial correlation functions are then valid in the range of experimental temperature. Graphical representation of experimental values of heat capacity as a function of temperature is given in Figure 4 for five samples and emulsion of buna-S. Graphical representations of percentage deviations of experimental values of heat capacity C_p with respect to the smoothing of eq 5 with coefficients of Table 12 as a function of temperature are given in Figure 5.

Conclusion

The automated adiabatic calorimeter developed for heat capacity from 240 K to 400 K was verified by measuring heat

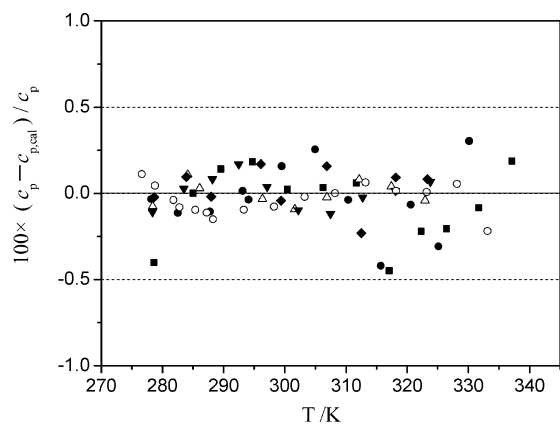

Figure 5. Percentage deviations of experimental values of heat capacities of five samples and the emulsion of buna-S with respect of the smoothing of eq 5 with the coefficients of Table 12 as a function of the temperature: ■, sample 1; ●, sample 2; □, sample 3; ▼, sample 4; □, sample 5; ○, emulsion of buna-S.

capacities of α - Al_2O_3 , heptane, and water. The maximum deviations of the results with literature values were 0.16 % for α - Al_2O_3 , 0.28 % for heptane, and 0.33 % for water, respectively. From the heat capacities of five mixtures used in the synthetic

process of buna-S and the emulsion of buna-S, 79 values of heat capacity were obtained.

Literature Cited

- (1) Tan, Z. C.; Ye, J. H.; Chen, S. X.; Zhou, L. X. An adiabatic calorimeter for heat capacity measurements in the temperature range 300 K–600 K and pressure range 0.1–15 MPa. *Thermochim. Acta* **1991**, *183*, 29–38.
- (2) Zubillaga, J.; López-Echarri, A.; Tello, M. J. An automated calorimeter for solid substances. *Thermochim. Acta* **1985**, *92*, 283–286.
- (3) Sauerland, E.; Helwig, J.; Müser, H. E. An automatic adiabatic calorimeter for intermediate and high temperatures. *Thermochim. Acta* **1983**, *69*, 253–267.
- (4) McCullough, J. P.; Scott, D. W. *Experimental Thermodynamics*, Vol. 1; Butterworths: London, 1968.
- (5) Ditmars, D. A.; Ishihara, S.; Chang, S. S.; Bernstein, G.; West, E. D. Enthalpy and heat capacity standard reference material: synthetic sapphire. (Al_2O_3) from 10 K to 2250 K. *J. Res. Natl. Bur. Stand.* **1982**, *87*, 159–163.
- (6) Douglas, B. T.; Furukawa, G. T.; McCoskey, R. E.; Ball, A. F. Calorimeter properties of normal heptane from 0 K to 520 K. *J. Res. Natl. Bur. Stand.* **1954**, *53*, 139–153.
- (7) The International Association for the Properties of Water and Steam. Release on the IAPWS formulation 1995 for the thermodynamic properties of ordinary water substance for general and scientific use. Fredericia, Denmark, September 1996.

Received for review July 2, 2005. Accepted February 14, 2006.

JE050252L